



Description

- Twin lever handle contemporary style hi-rise kitchen faucet
- Trouble-free brass frame ceramic cartridge
- 8" on-center 4 hole installation
- Brushed nickel finish
- All brass construction
- Includes color matched sprayer with 48" reinforced hose

Performance

- Designed to provide 2.2 GPM at 60 PSI

Compliance

- Designed to comply with requirements of ASME A112.18.1
- Meets low lead requirements of NSF Standard- 61, Section- 9
- Meets low lead requirements of California Proposition- 65
- Complies with the requirements of the UPC (Uniform Plumbing Code)
- Complies with ADA (American With Disabilities Act)
- Meets or exceeds CSA B125

Listings

- IAPMO (International Association of Plumbing & Mechanical Officials)
- UPC (Uniform Plumbing Code)
- CSA (Canadian Standards Association)
- NSF Certified (National Sanitation Foundation)

Warranty

- Limited Lifetime Warranty
Refer to Premier Faucet warranty program for further details and restrictions.

Sanibel™



Model 120047

Twin Lever Handle High-Rise Kitchen Faucet

Brushed Nickel Finish

With Sprayer

1/2" IPS Connection

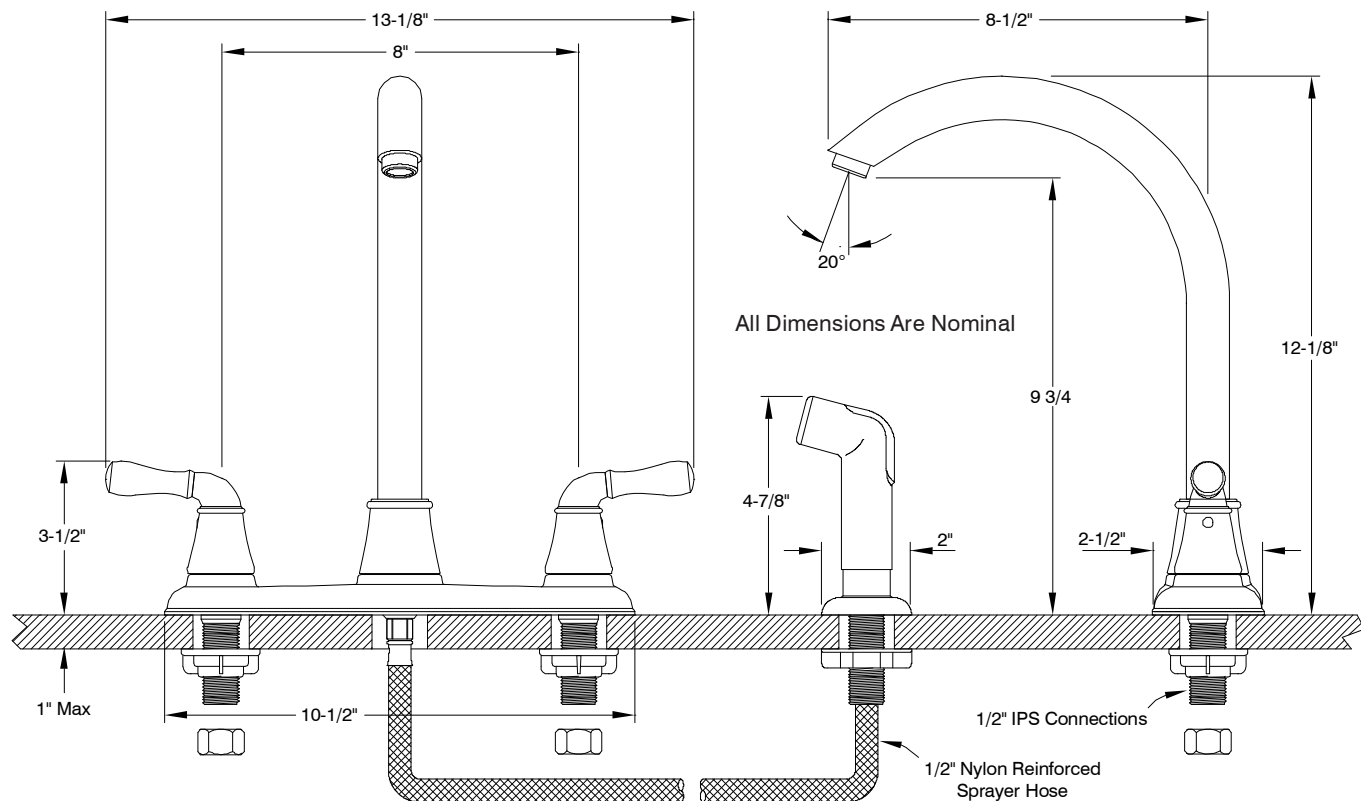

For additional information contact Premier Faucet at 866-745-4010 or visit our website at www.premierfaucet.com

